

Motorhome Seat

series 350

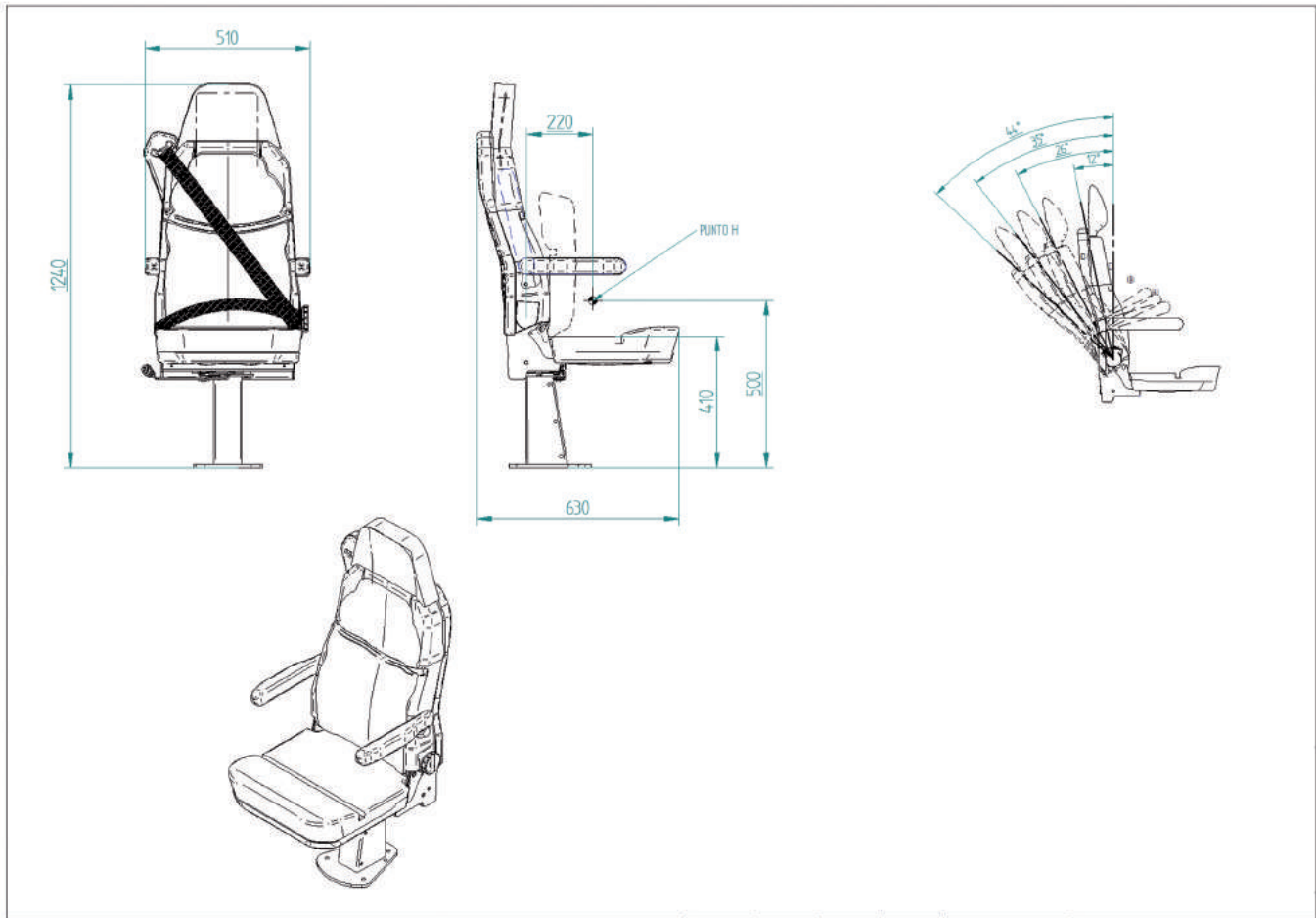



MULTIFUNKTION-SITZ GESAMTEN BESCHAFFENHEITEN

- Kopfstütze integriert
- verstellbare Rückenlehne
- integrierter 3-Punkt-Sicherheitsgurt
- verwendbar im hinteren Fahrzeugbereich
- maximale Optimierung des innen Wohnraums, Dank zu seinen kleinen Massen
- verschiedenen Farben moeglich fuer den Sitzbezug
- M1-geprueft

Optionen:

- Armlehnen
- Untergestell bestehend aus starren Fuessen sowie aus Einzelsockel (starr oder drehbar), lieferbar auch mit Schnellverschluss



SIÈGE MULTIFUNTIONCARACTÉRISTIQUES

- appui-tête intégré
- dossier réglable
- ceinture de sécurité à 3-points intégrée
- approprié pour l'installation dans l'arrière du véhicule. Ses dimensions réduites permettent l'optimisation maximal de place à l'intérieur
- large gamme des revêtements
- M1-testé

Options:

- accoudoirs
- support: 2 pieds fixe, socle fixe ou pivotant (centrale ou déplacé), disponible aussi avec deblocage rapide



MULTIPURPOSE SEAT MAIN FEATURES

- integrated headrest
- adjustable backrest
- integrated 3-points-safety belt
- suitable to fit the rear of the vehicle, its reduced dimentions enable the best optimization of the inside space
- many colours trimming
- M1-tested

Options:

- armrests
- seat support with legs, fixed pedestal or rotating pedestal (central or off-centred), also available in the quick-release version